

TORNADO® INDUSTRIES CORP.  
7401 W. LAWRENCE AVENUE  
CHICAGO, IL 60706  
(708) 867-5100 FAX (708) 867-6968  
www.tornadovac.com



---

## Operation & Maintenance Manual

For Commercial Use Only



## Wide Area Vacuum Cleaner

CATALOG NO.

**93031**

For Parts List see L3031ABP

## Specifications

<b>CATALOG NO.</b>	<b>93031</b>
SERIES	B
CLEANING PATH (WIDTH)	30"
HP – BRUSH MOTOR	½ HP
HP – VAC MOTOR	2 X 1 HP
VOLTS	230V
AMPS	15
CERTIFICATION	Pending

## TABLE OF CONTENTS

(L3031 MANUAL)

<u>DESCRIPTION</u>	<u>PAGE(S)</u>
Performance Features.....	2
Machine Specifications / Warranty.....	3
Safety / Grounding Instructions.....	4-6
Assembly Instructions.....	7-8
Bag Installation Instructions.....	9
Brush Height Adjustment Instructions.....	10
Basic Operation Instructions.....	11
Filter Replacement Instructions.....	12
Belt Adjustment / Replacement.....	13

### PERFORMANCE FEATURES:

- Advanced Styling With Durable Construction
- Clean Air Filtration
- 30" Wide Cleaning Path
- Height-Adjustable Folding Handle
- 4-Row Chevron Brush (28" Long x 3" Diameter)
- PMDC Brush Motor, ½ HP, 2600 RPM
- (2) Ametek Vacuum Motors:
  - 1 HP, 98 CFM, 63" Waterlift
- 4 Stage "Clean Air" Filtration:
  - Stage 1: Disposable Paper Bag
  - Stage 2: High Efficiency Reusable Cloth Bag
  - Stage 3: Vacuum Motor Intake Filter
  - Stage 4: Motor Exhaust Filter Cartridge
- Rotationally Molded Housing and Lid
- 10" Diameter, 125 Lb. Rated Main Wheels
- 5 Foot-operated Brush Height Adjustment Levels
- Easy Access Poly-V Drive Belt
- Stainless Steel Brush Shoe
- 75 Foot Power Cord

## Long-term buyer protection warranties

<b>Tornado® Standard Warranty Program*</b>	
<p>Warranties do not cover components subject to normal wear or abuse and misuse, and have other limitations not specified here. For full details, contact your Authorized Tornado Distributor, Service Center, or the Tornado Technical Service Department.</p> <p>Tornado sales and service representatives are not authorized to waive or alter the terms of this warranty, or to increase the obligations of Tornado under the warranty.</p>	<p><b>10 Years:</b> <i>All plastic tanks and rotationally-molded bodies<sup>1) 2)</sup></i></p>
	<p><b>2 Year:</b> <i>Parts on all Tornado and Tornado/Karcher cleaning equipment<sup>1) 2) 3)</sup></i></p>
	<p><b>1 Year:</b> <i>Labor on all Tornado and Tornado/Karcher cleaning equipment<sup>2)</sup></i></p>
	<p><b>1 Year:</b> <i>Warranty on batteries and chargers, one year pro-rated.</i></p> <p><b>** 6 Month Warranty on Gel Batteries</b></p> <p><b>All battery warranties are handled by the battery manufacturer, please call customer service for more information.</b></p>

Thank you for choosing Tornado products. We are proud to offer the most complete line of commercial and industrial cleaning equipment in the industry. Our reputation for quality, innovation and durability is unsurpassed.

Effective January 1<sup>st</sup>, 2005. Terms subject to change without notice.  
Windshear™ Blower-Dryer, Insulation Blowers, T191, T201, T12/1, CV 30, CV 38, CW 50, CW 100, Pro PAC Vacs, Duo-Upright Carpetkeepers™, Gas & Electric Pressure Washers, and all chargers are warranted for 1 (one) year for both parts and labor.  
Warranties on all riding sweepers including the ICC1, KM 100/100 R, KMR 1250, and KMR 1700 are 24 months parts/6 months labor OR 1000 hours of operation, whichever comes first. Warranties on the 75/140 & 90/140 are 24 months parts/12 months' labor OR 1,000 hours of operation whichever comes first.  
All non-wear item parts purchased after warranty expiration are warranted for 90 days.  
Warranty starts from the date of sale to the consumer or, at Tornado's discretion, 6 months after dealer purchased the unit from Tornado, whichever comes first.

Note: Tornado, The Latest Dirt, Floorkeeper, Carpetkeeper, Carpetrinser, Carpetrinser/Dryer, Headmaster, Taskforce, PAC-VAC, T-Lite, Glazer, Windshear, Max-Vac, CV 30, CV 38, and Trot-Mop are trademarks of Tornado Industries.

1-800-VACUUMS  
Chicago area: (708) 867-5100  
Fax: (708) 867-6968  
7401 W. Lawrence Avenue  
Chicago, IL 60706

**IMPORTANT SAFETY INSTRUCTIONS FOR  
COMMERCIAL USE ONLY**  
**WHEN USING AN ELECTRICAL APPLIANCE BASIC PRECAUTIONS SHOULD ALWAYS BE  
FOLLOWED INCLUDING THE FOLLOWING:**

**READ ALL INSTRUCTIONS BEFORE USING THE MACHINE**



**WARNING: To reduce the risk of fire, electric shock or injury:**

Do not leave machine unattended when plugged in. Unplug from outlet when not in use and before changing bags or attempting any maintenance or adjustment.

To avoid electrical shock, Use indoors only. Do not use outdoors and do not expose to rain.

Do not allow to be used as a toy. Close attention is necessary when used by or near children.

Use only as described in this manual. Use only manufacturer's recommended attachments.

Do not use with damaged cord or plug. If machine is not working as it should, has been dropped, damaged, left outdoors, or dropped into water, return it to a service center.

Do not pull or carry by cord, use cord as a handle, close a door on cord, or pull cord around sharp edges or corners. Do not run machine over cord. Keep cord away from heated surfaces. Do not unplug by pulling on cord. To unplug, grasp the plug not the cord. Do not handle plug or machine with wet hands.

Keep hair, loose clothing, fingers, and all parts of body away from openings and moving parts.

Turn off all controls before unplugging.

Connect to a properly grounded outlet only. See Grounding Instructions.

Do not put hands under base - rotating parts could cause injury. Always keep hands feet and loose fitting clothing away from moving parts to prevent possible injuries. Use care to keep electrical supply cable from contacting moving parts, such as floor brushes.

**Risk of explosion:** Use this machine only in a well ventilated area, free from any flame or match. Do not use machine in areas where flammable and/or explosive vapors or dust are present.

Make sure voltage and frequency at the wall power receptacle correspond with that indicated on name plate before plugging in machine. A 20 amp circuit is recommended.

Never use a device to lock the switch lever in the ON position.

Use only a 12 Ga. three-wire extension cable which have 3-prong grounding type plugs and 3-prong receptacles that accept the machine's plug.

**Save These Instructions**

## BEFORE OPERATING MACHINE



**WARNING:** Failure to adhere to these instructions could result in serious bodily injury or property damage.

Read this manual completely before attempting to operate machine. This manual has important information for the use and safe operation of the machine. Keep this manual on file and handy. If additional information is needed, please contact your local distributor or call:

**TORNADO INDUSTRIES**  
7401 W. LAWRENCE AVE.  
CHICAGO, IL 60706

(708) 867-5100  
1-800-VACUUMS  
Fax: (708) 867-6968  
<http://www.tornadovac.com>

## Grounding Instructions



**WARNING:** Improper connection of the equipment-grounding conductor can result in a risk of electric shock. Check with a qualified electrician or service person if you are in doubt as to whether the outlet is properly grounded. Do not modify the plug provided with the appliance - if it will not fit the outlet, have a proper outlet installed by a qualified electrician.

This appliance must be grounded. If it should malfunction or breakdown, grounding provides a path of least resistance for electric current to reduce the risk of electric shock. This machine is equipped with a cord having an equipment-grounding conductor and grounding plug. The plug must be inserted into an appropriate outlet that is properly installed and grounded in accordance with all local codes and ordinances.

This appliance is for use on a nominal 120-volt circuit, and has a grounding plug that looks like the plug illustrated in sketch A. A temporary adapter that looks like the adapter illustrated in sketches B and C may be used to connect this plug to a 2-pole receptacle (sketch B) if a properly grounded outlet is not available. The temporary adapter should be used only until a properly grounded outlet (sketch A) can be installed by a qualified electrician. The green-colored rigid ear, lug, or tab extending from the adapter must be connected to a permanent ground such as a properly grounded outlet box cover. Whenever the adapter is used, it must be held in place by a metal screw.

**NOTE:** In Canada, the use of a temporary adapter is not permitted by the Canadian Electrical Code.

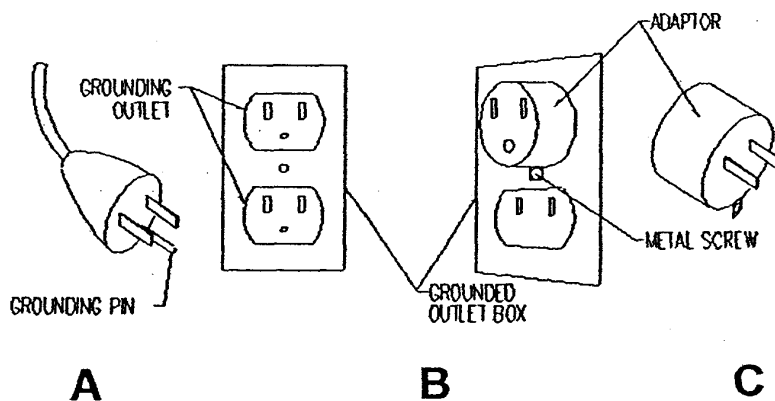

## EXTENSION CORD

If an extension cord is used, use only a three wire 12 gauge extension cord that has three prong grounding type plugs and three prong receptacles that accept the machine's plug. This machine is equipped with a 14 gauge power cord. Replace or repair all damaged cords.

### WHEN THE MACHINE IS DELIVERED

If machine is damaged, notify the carrier immediately and request an inspection. Be sure to keep the carton, packing inserts, packing lists, and carrier's receipt until the inspector has verified your claim.

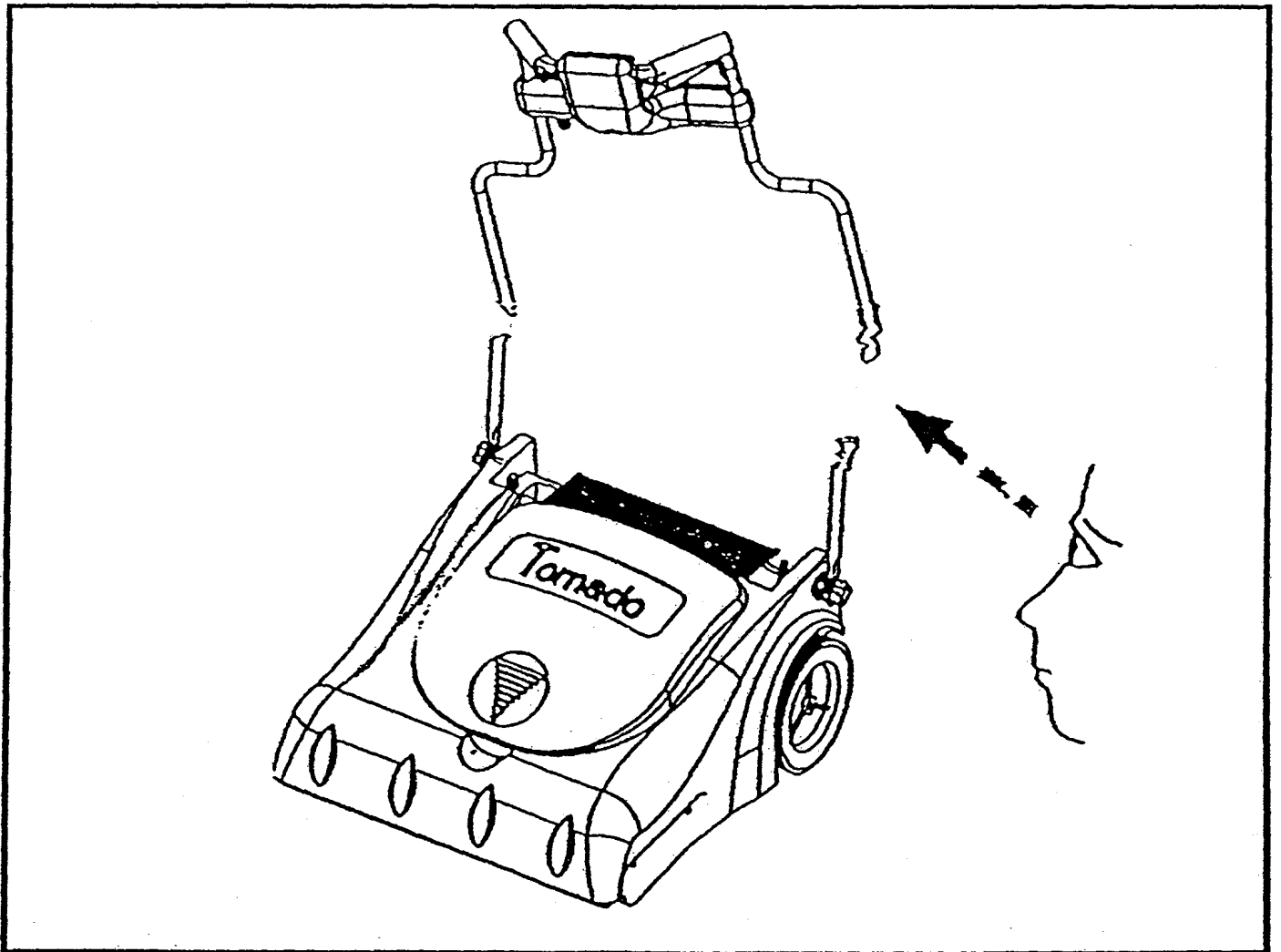
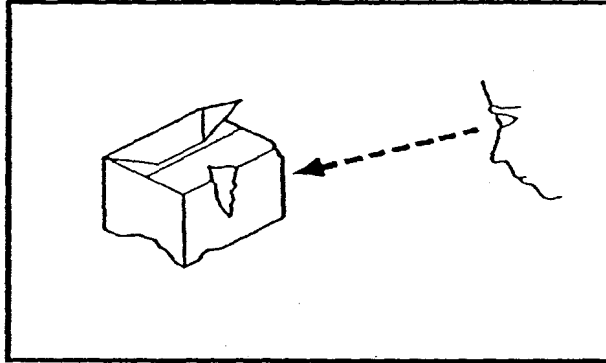

# ASSEMBLY INSTRUCTIONS:

1. Loosen handle pivot knobs and adjust handle to comfortable operation height.
2. Tighten knobs to lock handle in place.

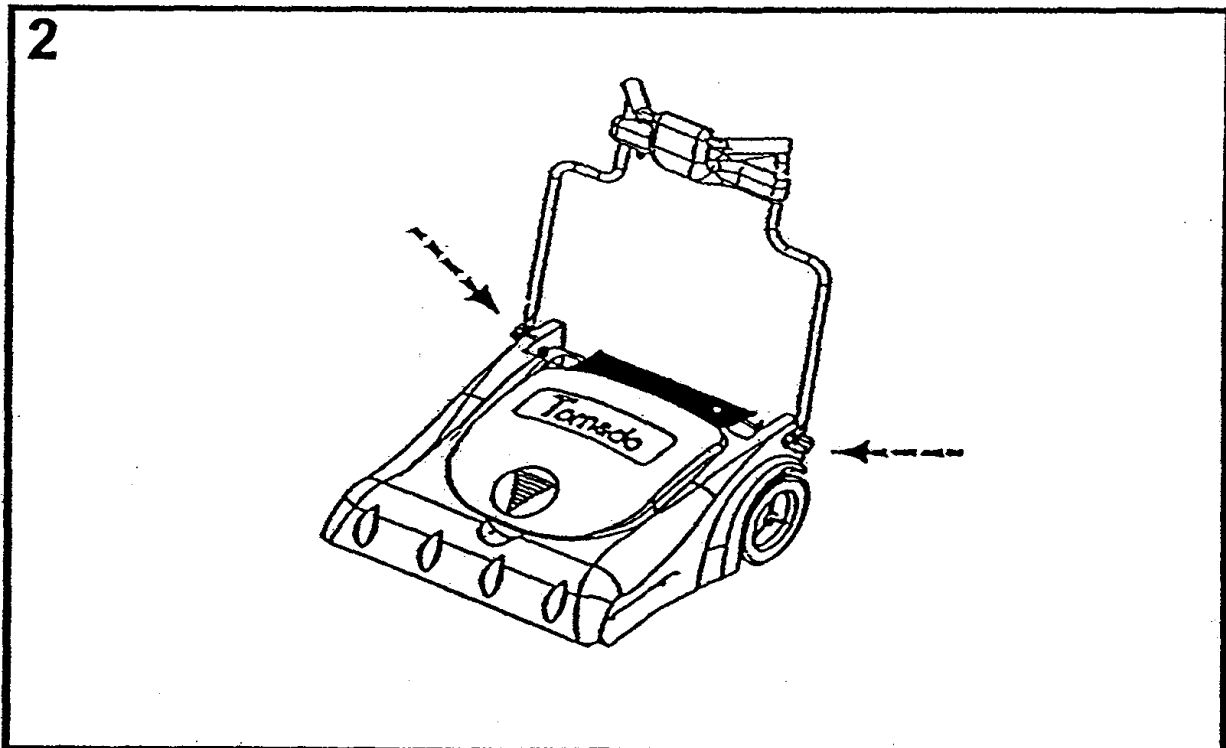
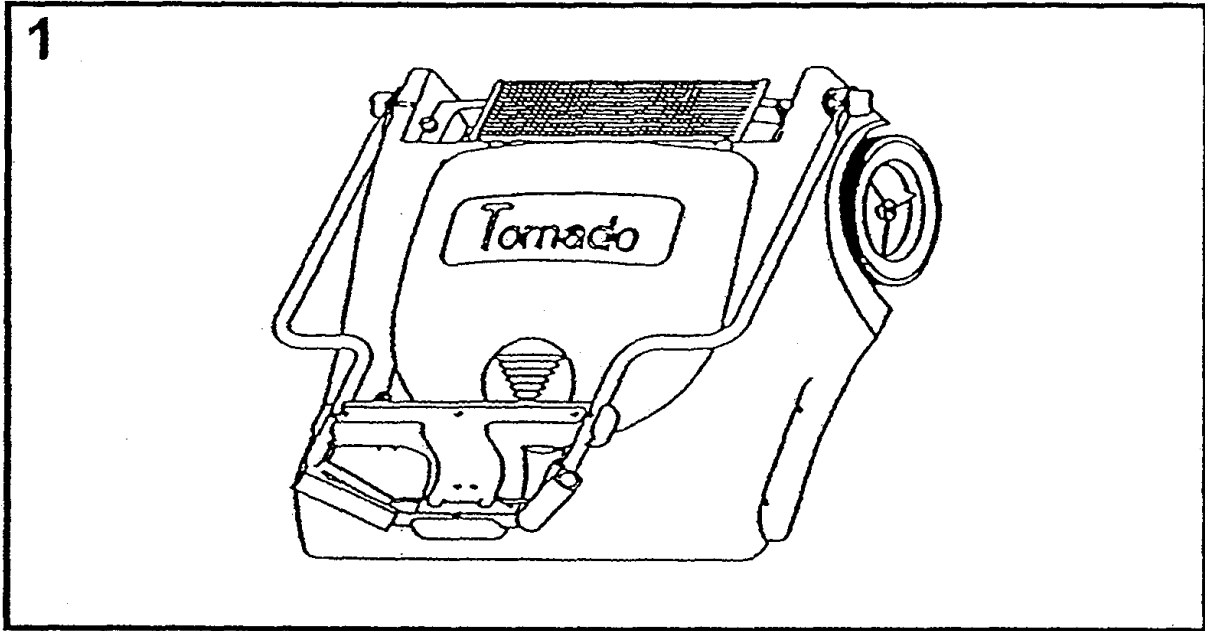



## **BAG INSTALLATION INSTRUCTIONS:**

1. Open Wide Area Vacuum lid.
2. Unzip cloth bag and install paper bag inside.
3. Attach both bag openings together onto vacuum intake housing (see diagram 3 below).
4. Make sure bag is properly deployed inside machine housing.
5. Completely close zipper on cloth bag and close lid of machine.

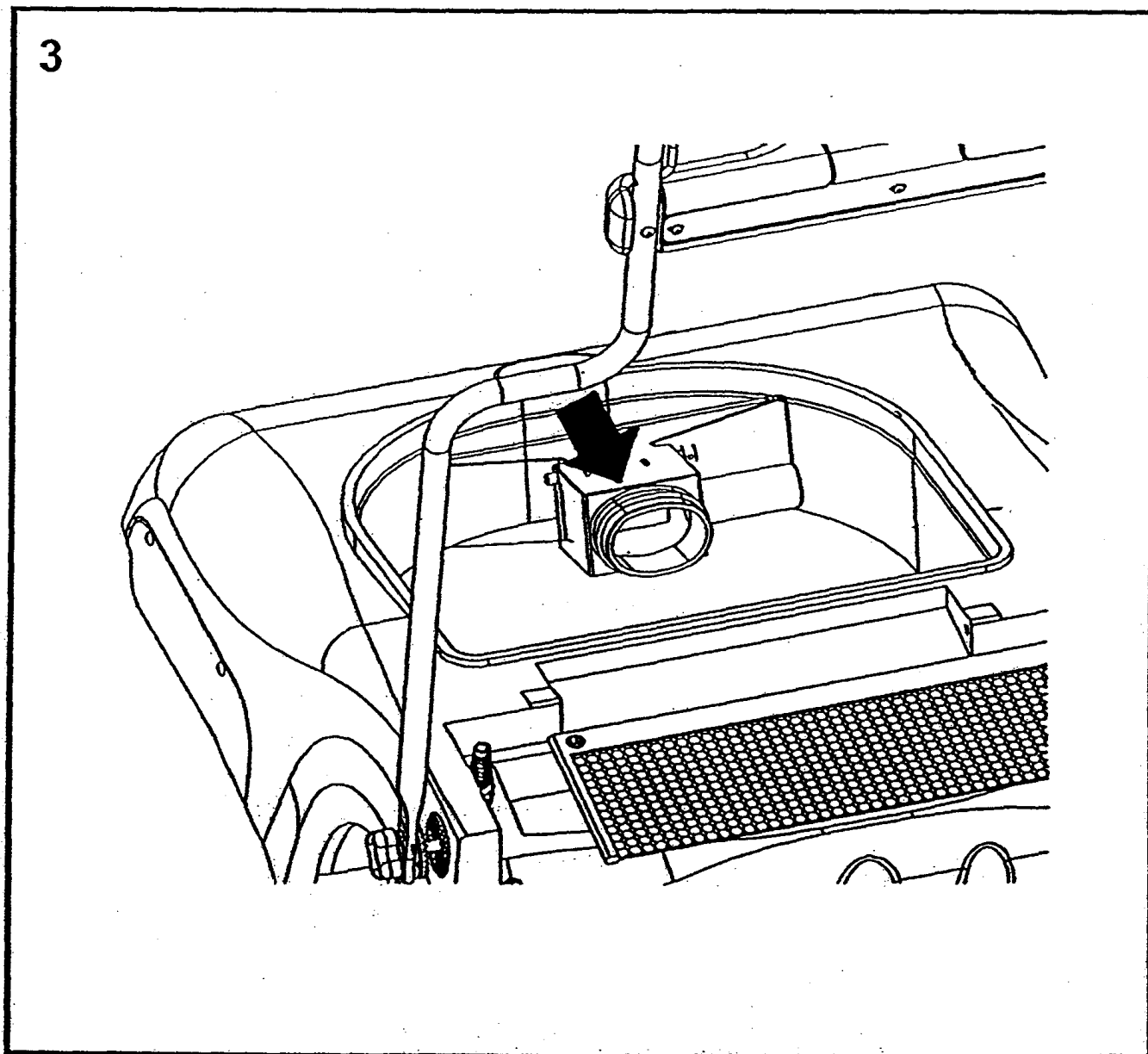

## BRUSH HEIGHT ADJUSTMENT:

1. This machine has 5 brush adjustment levels.
2. To raise brush height level: lift up height adjustment bar until desired brush height is attained (see diagram 4 below).
3. To lower brush height level: push down on height adjustment bar until desired brush height is attained (see diagram 5 below).

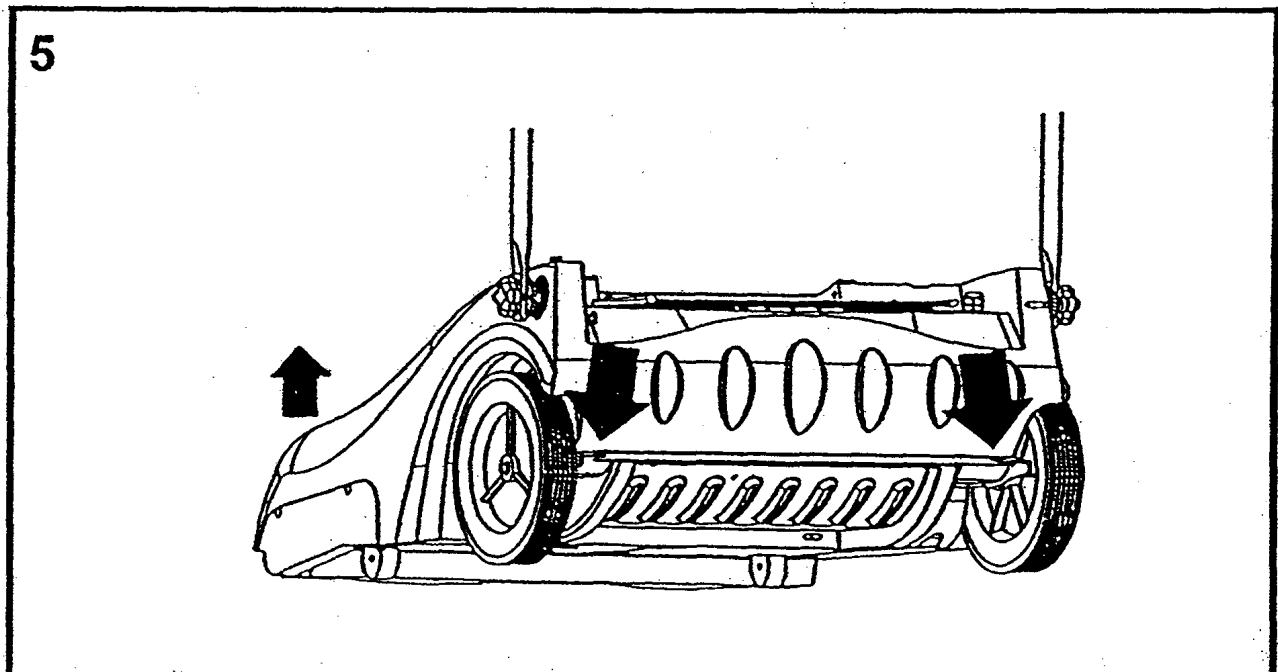
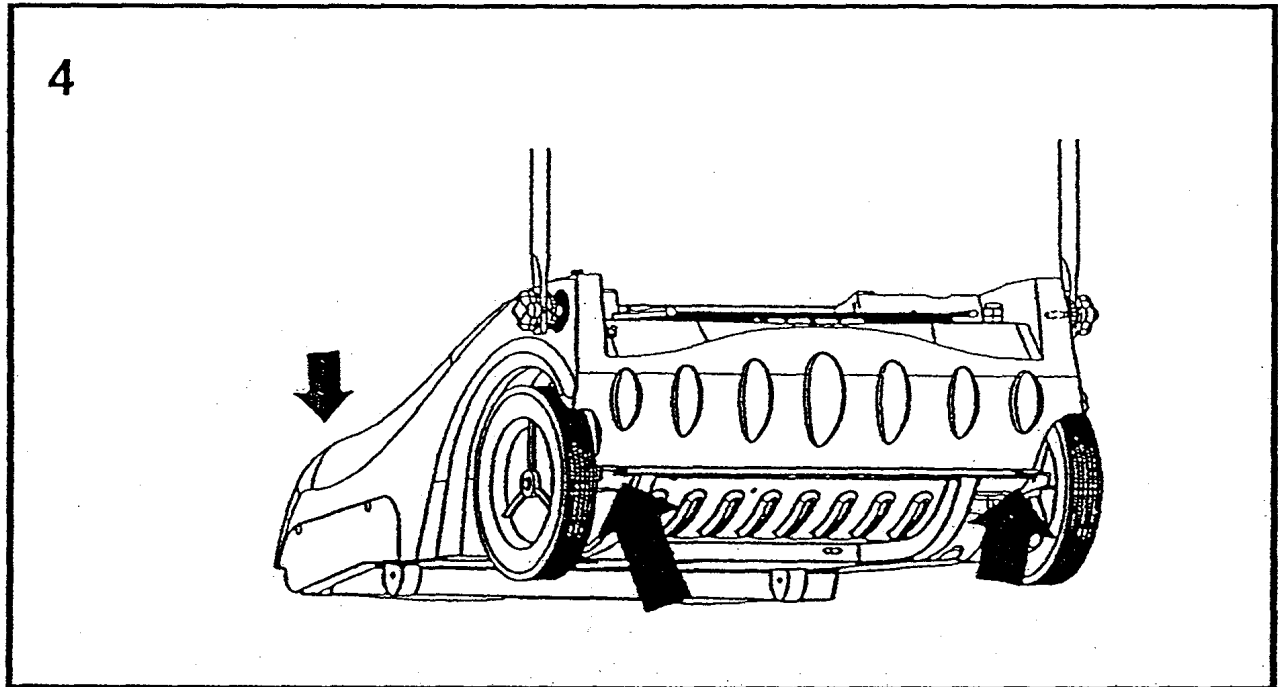

## OPERATION OF MACHINE:

1. Depress foot switch (located at rear left of machine) to turn on machine.
2. To operate brush squeeze trigger bar.
3. Adjust height for proper pick-up (refer to height adjustment instructions and diagram 6 below).

6.

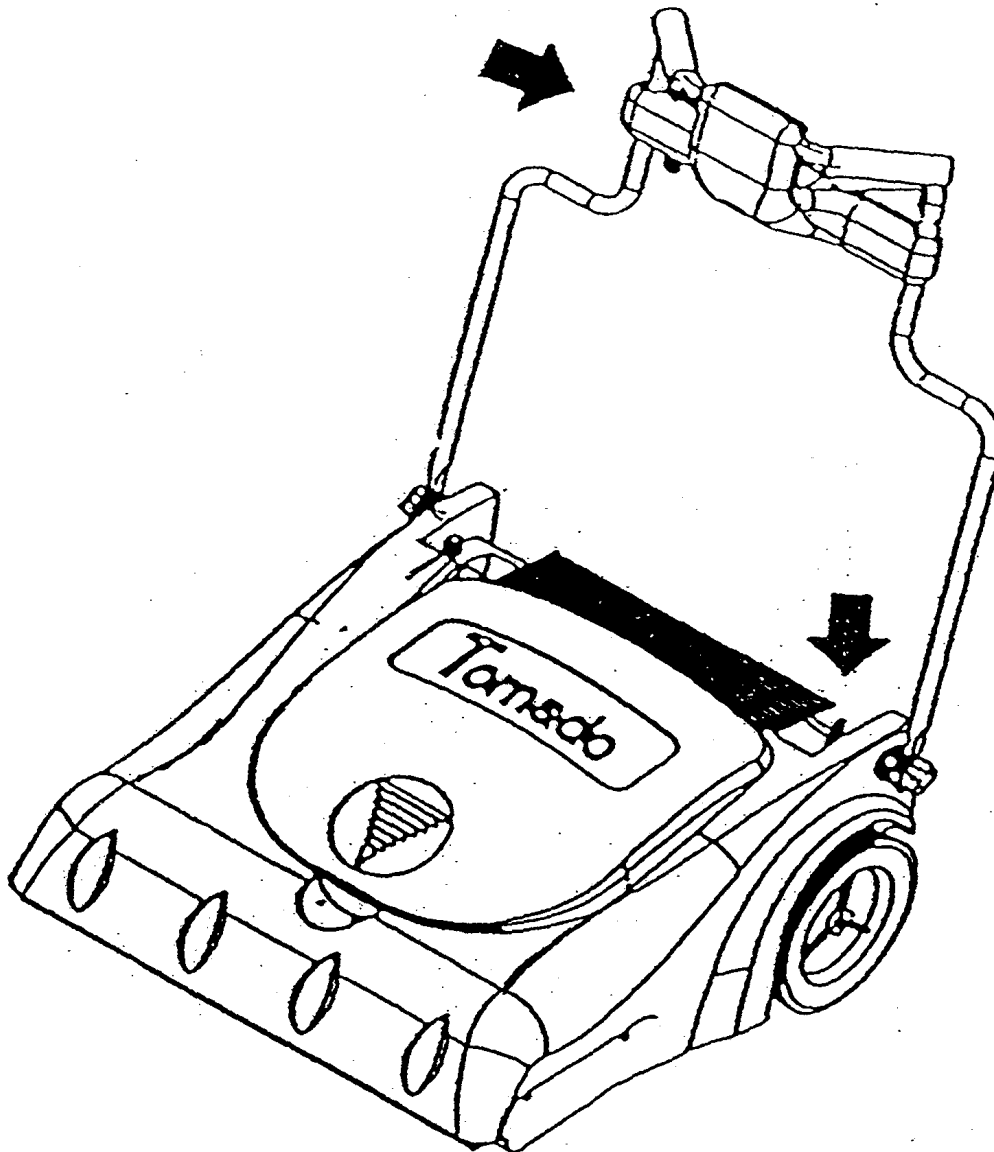

# FILTER REPLACEMENT:

1. Remove filter cover screws at back of machine (see diagram 7 below).
2. Remove the two nuts holding filter onto machine.
3. Replace filter in proper position and tighten nuts.
4. Reinstall filter cover.

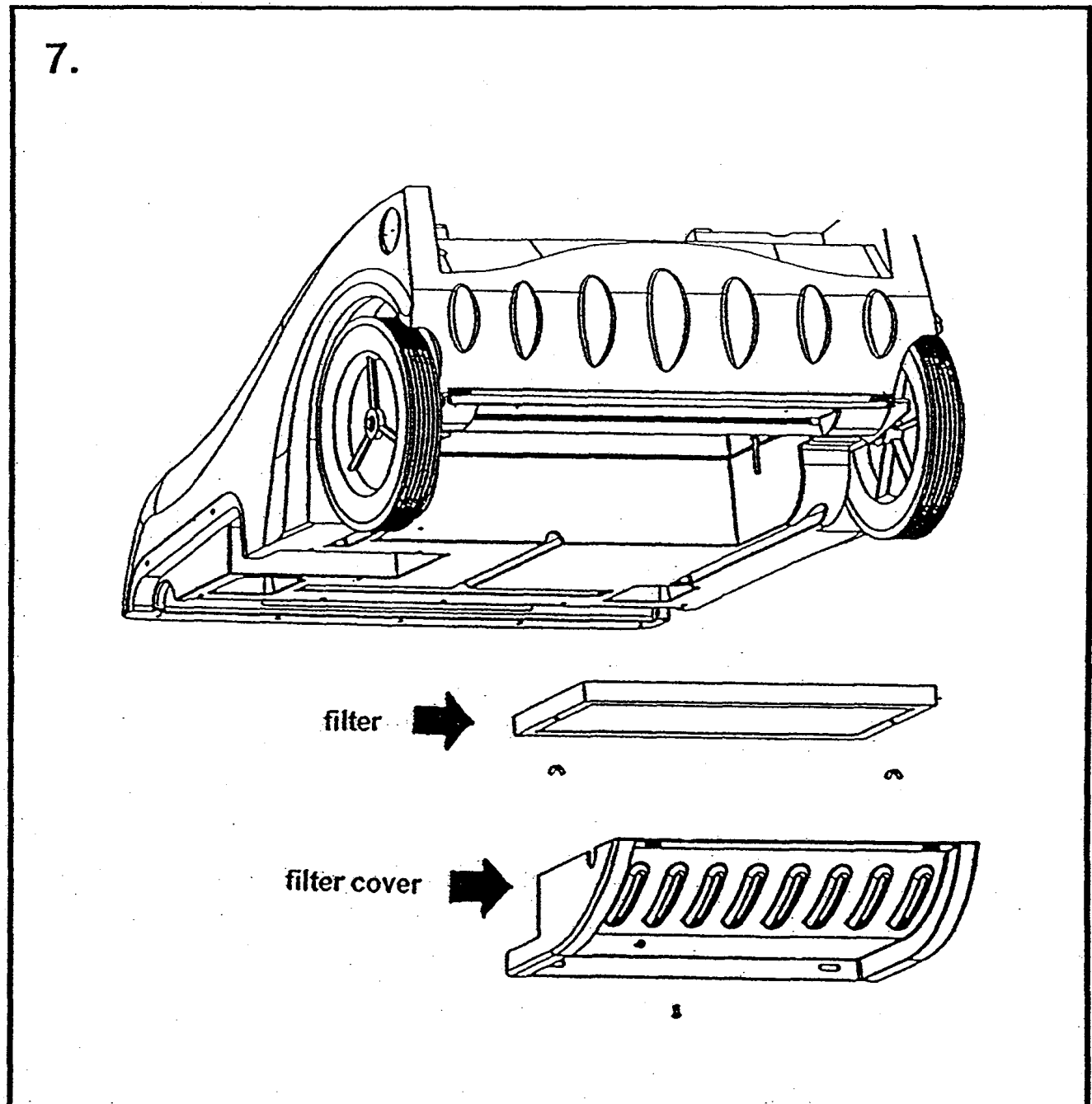

## BELT ADJUSTMENT

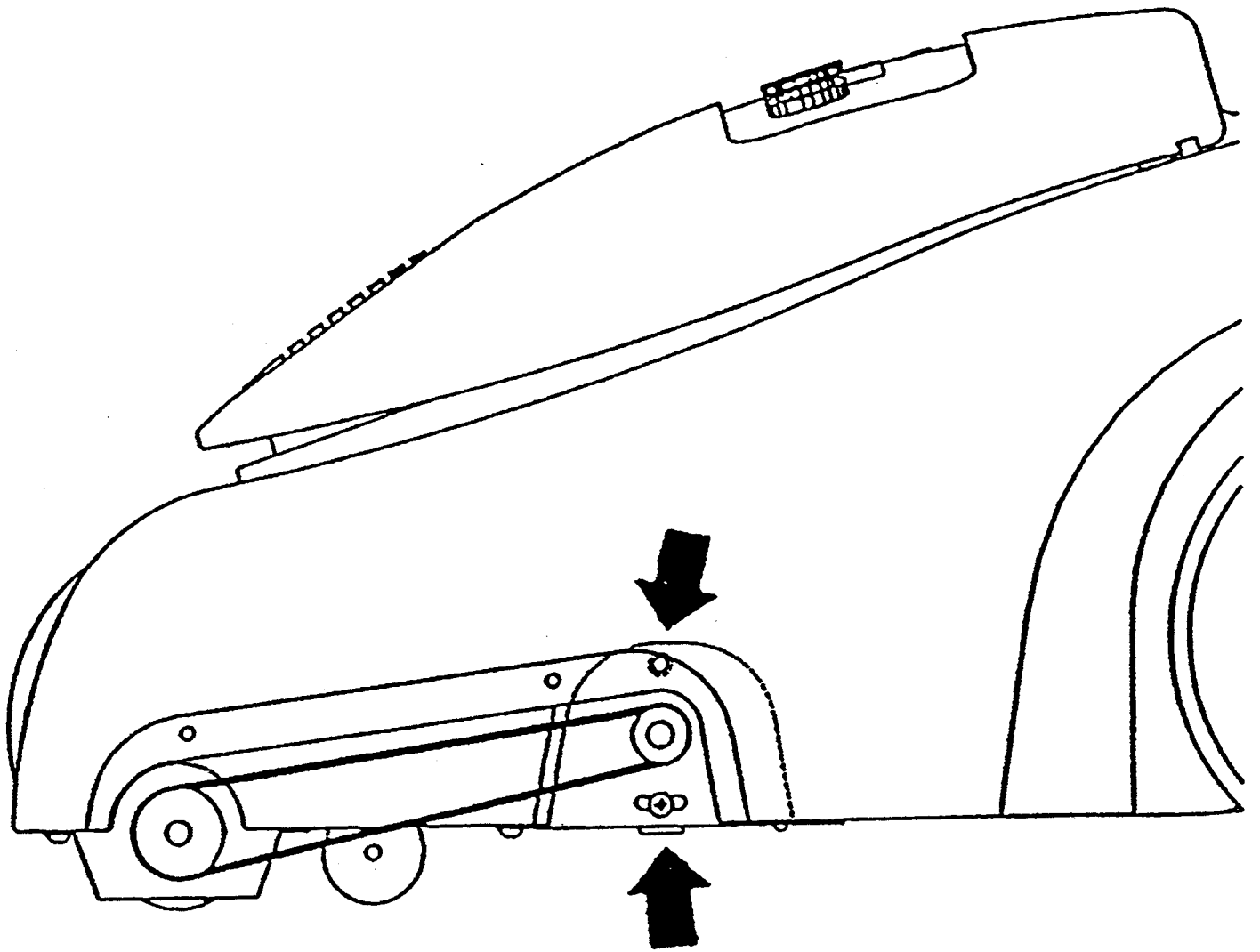

**Belt Adjusting Screws**